

206XDM

1/4" / 6 mm Straight Hand Tool Series



Light and quiet with ultra-low vibration magnitude at 1.43 m/s² r.m.s. Now you can replace your heavy noisy vibrating tools requiring lubrication and maintenance. At **0.4 HP (0.3 kW)** our patented double turbine **206XDM** with trigger switch for quick-shut off punches way above its weight of **14.25 oz (0.4 kg)**. Work with governed high speed which stays near rated speed under load at constant **50,000 RPM**. You will get superb surface quality and virtually no stress or noise. Try this tool – it transforms the operator's experience.

206XDM Dimensions

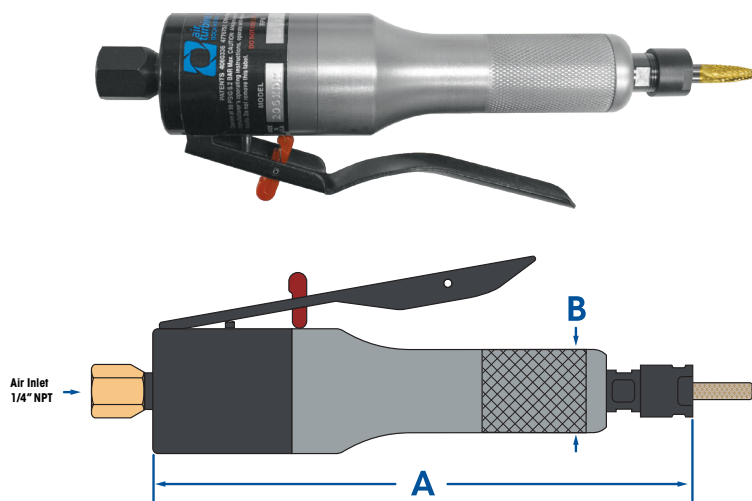

All fittings, couplings, and hoses must have a minimum of 6 mm internal diameter.

A	6.73" (171.02 mm)	B	Ø 1.0" (25.4 mm)
----------	-------------------	----------	------------------

206XDM Specifications

Speed	40,000 RPM	50,000 RPM
Power Rating	0.3 HP (0.22 kW)	0.4 HP (0.3kW)
Inlet Air Pressure	90 psi (6.2 bar)	
Air Consumption Idle	6 CFM (2.83 L/s)	
Air Consumption Working Flow	7 CFM - 10 CFM (3.3 L/s - 4.27 L/s)	
Air Hoses and Fittings Minimum Size	6 mm internal diameter	
Sound Level	Less Than 67 dBA	
Max Shank Capacity	1/4" (6 mm)	
Hand Tool Weight	14.25 oz (0.4 kg)	

206XDM Vibration Statistics

Time to reach Exposure Action Value 2.5 m/s ² A(8)	24 hours, 28 minutes
Time to reach Exposure Limit Value 5 m/s ² A(8)	97 hours, 51 minutes
Vibration Magnitude	1.43 m/s ² r.m.s

206XDM Part Numbers

1/4"		6 mm	
Speed	Part Number	Speed	Part Number
40,000 RPM	42976	40,000 RPM	42982
50,000 RPM	42979	50,000 RPM	42983
1/4" with brake		6 mm with brake	
Speed	Part Number	Speed	Part Number
40,000 RPM	42979	40,000 RPM	42985
50,000 RPM	42980	50,000 RPM	42986

Accessories

Model	Part Number
High Flow Filter	30004
High Flow Filter / Regulator	30003
High Flow Filter / Regulator / Extractor	30008
5' Air Supply Assembly w/Fitting for DM Models	30010
8' Air Supply Assembly w/Fitting for DM Models	30011

Equipment Included

- 206XDM Hand Tool
- Collet System (1/4" or 6 mm standard)
- Collet Wrenches
- Rear Exhaust
- Trigger Switch
- 1/4" NPT Air Supply Fitting

Standard Equipment

1/4" or 6 mm collet standard, other sizes are available.
Oil-free 90 psi / 6.2 bar clean, dry air supply required.

Tel:+1.561.994.0500 • www.airturbine.com • ask@airturbine.com

Supply is subject to Air Turbine Technology Inc. (ATT) distributor policies and upon terms and conditions contained in the ATT distributor agreement. Subject to availability, change of specifications, price and terms without notice. Always use a 0.3 micron filter/extractor and check specified air flow. 6.2 bar / 90 psi clean, dry, oil-free air only. Use eye protection and follow safety instructions. All specifications approximate. All tools are tested and rated to be within 10% of designated speed. © 2026 Air Turbine Technology, Inc. All rights reserved.

Initial Installation

Install a new dedicated clean air line from a filter/regulator to your Air Turbine Tool® as shown below. A 0.3 micron filter/regulator/extractor combination is a **highly recommended** accessory to operate Air Turbine Tools to eliminate all impurities in your air supply.

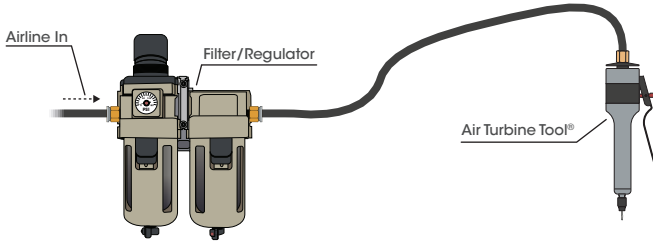

Air flow restrictions (such as air leaks and obstructions) will cause underpowered performance and drag your tool through the material, damaging the bearings. **Some fittings with nominal internal dimensions may have an ID passage that is smaller than stated and restrict air flow and power.** It only takes one fitting with an internal diameter that is too small to reduce air flow and power of your Air Turbine Tool®.

Air Requirements

Ensure there is sufficient volume of clean compressed air flow at **90 psi (6.2 bar) with 7 CFM - 10 CFM (3.3 L/s - 4.27 L/s)** to maintain working air consumption. Our governor increases air flow volume on demand to keep rotation at the high speed when your tool starts to cut. **Air pressure and flow volume must therefore be available on demand and remain constant with no drop over time or when cutting.**

Avoid pressure below 90 psi (6.2 bar), which causes the tool to be dragged through the material, causing rapid bearing wear and underpowered performance. Do not use more than 100 psi (6.9 bar) pressure which will burst the turbine power producer.

Air pressure and flow must remain constant with no drops under cutting load. Insufficient flow will cause the rotation of your tool to slow or stop suddenly, damaging the bearings.

If a drop in psi (bar) occurs below 90 psi (6.2 bar), your compressor may not have enough CFM (L/s) to power the Air Turbine Tool® or there is a flow restriction in the air line.

Maintenance

Your Air Turbine Tool® must be run at least 10 minutes every 30 days from manufacture date to maintain optimal performance. **Run at least 10 minutes before initial use.** This will ensure the bearing lubrication does not solidify. The airline must be impeccably clean with no coupling or hose smaller than **8 mm** so that air flow volume is unrestricted.

Purge the airline of contamination before each use.

A 0.3 micron filter/regulator/extractor combination is a **highly recommended** accessory to operate Air Turbine Tools® to eliminate all impurities in your air supply. Refer to the accessories table on the other side of this sheet for filters/regulators/extractors that are compatible with the **206XDM**.

Contamination of your turbine components will damage your turbine and require repair. **Filter elements need to be changed periodically and the regulator and extractor must be drained in regular maintenance cycles.**



WARNING
Always use proper eye protection while operating your Air Turbine Tool®.



WARNING
Do not clamp Air Turbine Tool® hand tools into a fixture. This will cause distortion in the bearing race, damaging the tool and voiding the warranty.

Operation

Always monitor the air pressure gauge during operation of your Air Turbine Tool®. All tools are tested and rated to be within 10% of the designated speed.

Do not try to cut too aggressively. You will overload your turbine causing your cutting tool to stall or drag in the material. Dragging your tool on the work or a sudden stop will cause stress to the bearings and force the grease out, causing premature failure.

Select The Correct Cutting Tool

Ensure your cutting tool is rated for the rotational speed you are using. **Your tool must be balanced and truly concentric to operate at the high speed of Air Turbine Tools®.**

Incorrect tool selection results in unbalanced rotation or overloading, which will result in stress on the bearings and premature failure.

The stick-out extension length of the cutting tool from your collet should be no more than 3 times the diameter of the cutting tool from the collet.

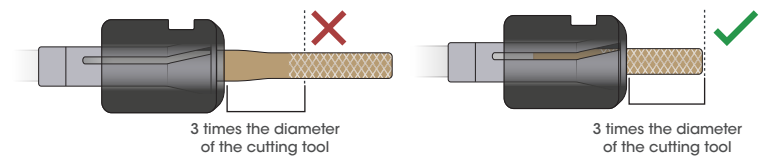

Properly Turning Your Tool On and Off

To turn on your tool, squeeze the trigger switch when an airline is connected as shown below. The tool will only operate when the trigger switch is squeezed.

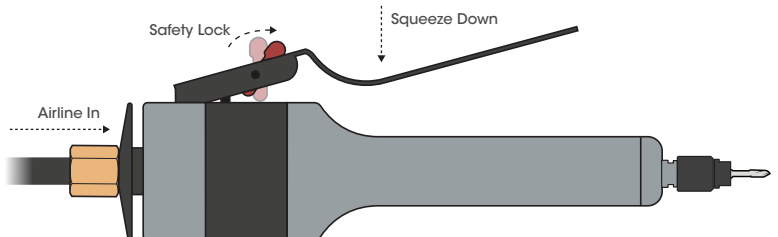

Never Stall Your Tool

A sudden stop or stalling your hand tool will cause stress to the bearings and force the grease out of them.

Operate The Tool Safely

Comply with general industry safety & health regulations, part 1910 and 2206 OSHA, etc. Federal, state and local regulations and laws in your country. Ensure that you operate your Air Turbine Tool® in compliance with safety code for portable air tools - ANSI 186.1, etc.



**Scan to consult
full user instructions.**