

At 65,000 rpm the 822MX keeps high speed under load. This compact low vibration live tool spindle operates 24/7 with low heat and has just 2 moving parts and no gears, vanes, or high frequency brushes to burn up.

Drop in the 822MX to accelerate your production and increase your productivity. Ideal for lathes, swiss automatics, robotics and finishing with micro tools. No control system or maintenance.

Mountable area of Ø 22 mm OD by 50.55 mm. Completely sealed with hose exhausts.

822MX Dimensions

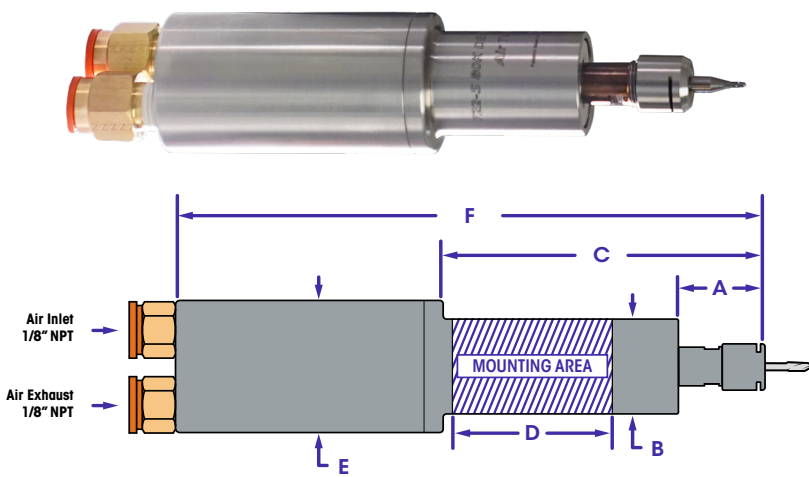

All fittings, couplings, and hoses must have a minimum of 5 mm internal diameter.

A	0.65" (16.51 mm)	C	2.03" (51.56 mm)	E	Ø 1.18" (30 mm)
B	Ø 0.85" (21.6 mm)	D	1.99" (50.55 mm)	F	4.99" (126.75 mm)

822MX Specifications

Speed	50,000 RPM	65,000 RPM
Power Rating	0.2 HP (0.15 kW)	
Inlet Air Pressure	90 psi (6.2 bar)	
Air Consumption Idle	4 CFM (1.89 L/s)	
Air Consumption Working Flow	6 CFM (2.83 L/s) - 9 CFM (4.24 L/s)	
Air Hoses and Fittings Minimum Size	5 mm internal diameter	
Sound Level	Less Than 78 dBA	
Max Shank Capacity	ER8 UP - 1/8" (3mm)	
Live Tool Weight	13 oz (0.37 kg)	

822MX Series Part Numbers

ER8 UP - 1/8"		ER8 UP - 3 mm	
Speed RPM	Part Number	Speed RPM	Part Number
50,000	70162	50,000	70163
65,000	70164	65,000	70165

Accessories

Model	Part Number
Low Flow Filter Regulator / Extractor	30006
Tube 8 mm O.D. - 5 mm I.D. (order by foot)	16506
Hose & Fitting - 6 mm O.D. - 4 mm I.D. - 12'	30041

Equipment Included

- 822MX Air Turbine Live Tool®
- ER8 UP Collet System (1/8" or 3 mm)
- Collet Wrenches
- Low Flow Filter Regulator / Extractor
- Fittings
- Air Hose
- Carrying Case

Standard Equipment

ER8 UP collet system (1/8" or 3 mm collet).

Oil-free 90 psi / 6.2 bar clean, dry air supply required.

Initial Installation

Install a new dedicated clean air line from the included filter/regulator to your Air Turbine Live Tool® as shown below. **Ensure all air lines, couplings and fittings meet the minimum internal diameter (ID) of 5 mm.** If working in a wet environment be sure to install exhaust hoses as shown below. Internal diameters of exhaust hoses must be no smaller than 5 mm internal diameter. Any connections smaller than 5 mm will restrict air flow and reduce power to your 822MX.

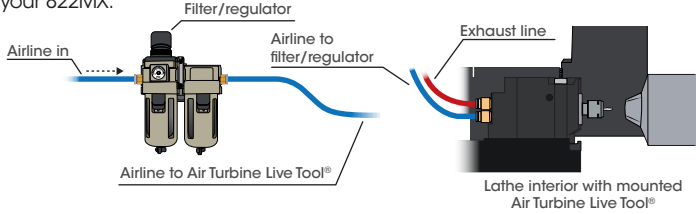

Air flow restrictions (such as air leaks and obstructions) will cause underpower performance and drag your tool through the material, damaging the bearings. **Some fittings with nominal internal dimensions may have an internal diameter passage that is smaller than stated and restrict air flow and power.** It only takes one fitting with an internal diameter that is too small to reduce air flow and power of your Air Turbine Live Tool®.

Air Requirements

Do not oil or lubricate. Use dry, clean, oil free 90 psi (6.2 bar) air supply only. Ensure there is sufficient volume of clean compressed air flow at 90 psi (6.2 bar) with **6 CFM (2.83 L/s) - 9 CFM (4.24 L/s)** to maintain working air consumption. Depending on application, consider peak or stall capacity consumption.

Our patented governor increases air flow volume on demand to keep rotation at the high speed when your tool starts to cut. Air pressure and flow volume must therefore be available on demand and remain constant with no drop over time or when cutting. Avoid pressure below 90 psi/6.2 bar, which causes the tool to be dragged through the material, causing rapid bearing wear and underpowered performance. Do not use more than 100 psi/6.9 bar pressure which will burst the turbine power producer. Air pressure and flow must remain constant with no drops under cutting load. Insufficient flow will cause the rotation of your tool to slow or stop suddenly, damaging the bearings. If a drop in psi (bar) occurs below 90 psi (6.2 bar), your compressor may not have enough CFM (L/s) to power the Air Turbine Live Tool® or there is a flow restriction in the air line.

Mounting your Air Turbine Live Tool®

It is very important your fixture is not clamped over the bearings. Incorrect positioning or over tightening of the clamp on your Air Turbine Live Tools® steel barrel results in pressure on the bearings causing premature failure. To avoid this error in installation refer to the dimensional drawing for your model on the other side of this page.

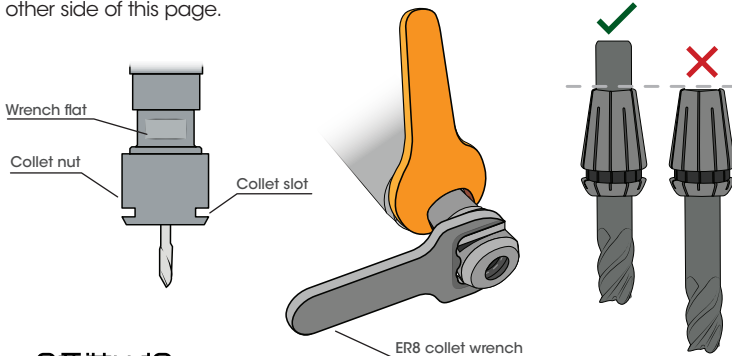

Scan to consult full user instructions.

Maintenance

Your Air Turbine Live Tool® must be run at least 10 minutes every 30 days from manufacture date to maintain optimal performance. Run at least 10 minutes before initial use. The airline must be impeccably clean with no coupling or hose smaller than 5 mm internal diameter. The included 0.3 micron filter extractor regulator combination is a necessary accessory for Air Turbine Live Tools® to eliminate impurities in your air supply. Contamination will damage your turbine components and require repair. **Filter elements need to be changed periodically and extractor drained in regular maintenance cycles.** Replacement elements and a repair service are available on our website.

Operation

Purge the line of contamination and run at least 10 minutes before initial use to ensure the bearing lubrication does not solidify.

Always monitor the air pressure gauge during operation of your Air Turbine Live Tool®. The key to successful high-speed machining and optimized tool performance is to program light passes at very high feed rates. Start with a light pass observing surface finish quality and gradually step down or increase your rate of advance for optimal cutting conditions. Do not try to cut too aggressively. You will overload your turbine causing your cutting tool to stall or drag in the material. Dragging your tool on the work or a sudden stop will cause stress to the bearings and force the grease out, which will require a repair.

Air Turbine Live Tools® are sealed for wet environments. In a wet environment, turn on the air supply to your 822MX **before** you turn on the coolant flow. **At the end of the cycle turn the coolant off first.** Only after the coolant flow is off, **then** you can turn off the air flow to your tool.

Selecting the Correct Cutting Tool

Air Turbine Live Tools® are for use with micro and small tools requiring high speed. Ensure your cutting tool is rated for the rotational speed you are using. The 822MX runs at 50,000 or 65,000 RPM. Your tool must also be balanced and truly concentric to operate at the high speed of Air Turbine Live Tools®. Incorrect tool selection results in unbalanced rotation or overloading, which will result in stress on the bearings and premature failure. The stick-out extension length of the cutting tool from your collet should optimally be no more than 3 times the diameter of your cutting tool.

Installation or Removal of Collet and Cutting Tool

1. Take the wrench included with your Air Turbine Live Tool® and insert it to the wrench flat of your Air Turbine Tool's shaft.
2. Take the ER8 collet wrench included with your Air Turbine Live Tool® and apply it on the collet slot as shown in the left diagram. Turn the wrench counterclockwise to release the current cutting tool.
3. After the cutting tool is free, continue to turn the collet nut counterclockwise with the ER8 collet wrench to fully remove the collet nut and release the existing collet. Remove the wrench from the shaft.
4. Remove the existing collet from the shaft and replace it with the new collet. Re-apply the collet nut by turning it clockwise on the shaft. **The 822MX requires 4 ft-lbs of torque to tighten.**
5. Insert the new cutting tool by sliding it into the shaft of your tool. Ensure that the new cutting tool goes completely through the collet as shown to the left. **The stick-out extension length of the cutting tool from your collet should optimally be no more than 3 times the diameter of your cutting tool.**
6. Re-insert the wrench onto the wrench flat of your Air Turbine Tool's shaft and turn the collet nut clockwise until it's firmly held. **Do not over tighten the collet nut.** The 822MX requires 4 ft-lbs of torque to tighten.
7. Insert the collet wrench into the collet nut and turn it clockwise to ensure the new collet and cutting tool is firmly held.



WARNING

Connection to air supply starts motor rotation. Do not connect air to your tool until installation is complete.