

Medical, aviation, and metalworking industries increase productivity dropping the **822CX** into Automatic Lathes. These sliding headstock lathes operate 7 days a week under enormous cost and time pressure. Economic production success depends on the speed and reliability of motor drive but the outdated motor technology has restricted productivity and resulted in high costs.

The **822CX** series operates 24/7 at 60,000/80,000 rpm accelerating your production rate. This powerful patented spindle has a governor which maintains your rated speed in the cut. Air Turbine Live Tools® are low friction direct drives with only 2 moving parts resulting in no heat and great reliability at high speed. Just connect 90 PSI, 6.2 Bar dry clean air supply, and mill on your Automatic.

### 822CX Dimensions

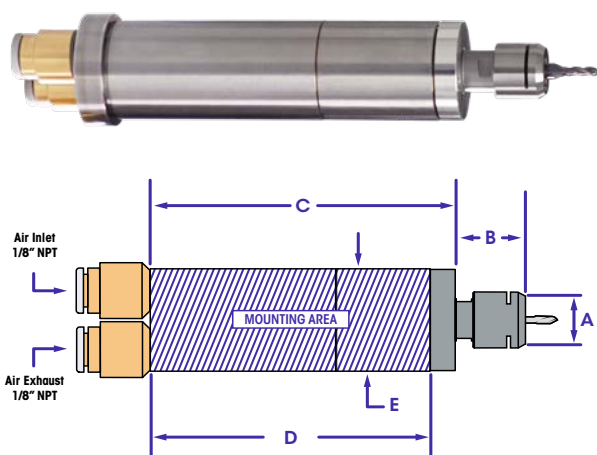

All fittings, couplings, and hoses must have a minimum of 4mm internal diameter.

A	Ø 0.47" (12mm)	C	3.09" (78.36mm)	E	Ø 0.86" (22mm)
B	0.72" (18.29mm)	D	2.9" (73.53mm)		

### 822CX Specifications

Speed RPM	60,000	80,000
Power Rating hp (kW)	0.15 (0.11)	
Inlet Air Pressure	90 PSI (6.2 Bar)	
Air Consumption Idle cfm (l/s)	3.5 (1.65)	
Air Consumption Working Flow cfm (l/s)	5 (2.36)	
Air Hoses and Fittings Minimum Size	4mm ID	
Sound Level	Less Than 78 dBA	
Max Shank Capacity	ER 8 UP - 1/8" (3mm)	
Live Tool Weight	5.6 oz (0.158 kg)	

### 822CX Series Part Numbers

ER8 UP - 1/8"		ER8 UP - 3mm	
Speed RPM	Part Number	Speed RPM	Part Number
60,000	80008	60,000	80009
80,000	80010	80,000	80011

### Accessories

Model	Part Number
Low Flow Filter Regulator / Extractor	30006
Tube 6mm O.D. - 4mm I.D. (order by foot)	16520
Hose & Fitting - 6mm O.D. - 4mm I.D. - 12'	30041

### Equipment Included

- 822CX Air Turbine Live Tool®
- ER 8 UP Collet System (1/8" or 3mm)
- Collet Wrenches
- Low Flow Filter Regulator / Extractor
- Air Hose
- Fittings
- Carrying Case

### Standard Equipment

ER 8 UP Collet System (1/8" or 3mm collet.)

Oil-free 90 psi / 6.2 bar clean, dry air supply required.