

732MX

Sealed Steel Series



The popular **732MX** is ideal for lab mills, lathes and swiss automation, and all fixture and robotic applications. Reach deep and run faster for accelerated production and cleaner cutting action.

Get finer finished surfaces with faster cycle times. Lower vibration and greater reliability result from fewer moving parts in this direct drive, oil free geared double turbine motor.

Mountable area of \varnothing 32mm OD by 95mm. Completely sealed with hose exhausts.

732MX Dimensions

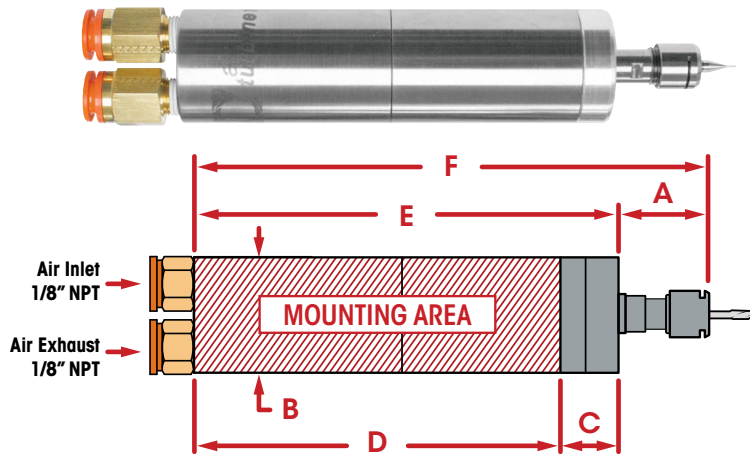

All fittings, couplings, and hoses must have a minimum of 5mm internal diameter.

A	0.91" (23.03mm)	C	0.60" (15.24mm)	E	4.34" (110.35mm)
B	\varnothing 1.26" (32.00mm)	D	3.74" (95.11mm)	F	5.25" (133.35mm)

732MX Specifications

Speed RPM	50,000	65,000
Power Rating hp (kW)	0.20 (0.15)	
Inlet Air Pressure	90 PSI (6.2 Bar)	
Air Consumption Idle cfm (l/s)	4 (1.89)	
Air Consumption Working Flow cfm (l/s)	6 (2.83) - 9 (4.24)	
Air Hoses and Fittings Minimum Size	5mm ID	
Sound Level	Less Than 78 dBA	
Max Shank Capacity	ER 8 UP - 1/8" (3mm)	
Motor Weight	18 oz (0.51 kg)	

732MX Series Part Numbers

ER8 UP - 1/8"		ER8 UP - 3mm	
Speed RPM	Part Number	Speed RPM	Part Number
50,000	70104	50,000	70105
65,000	70108	65,000	70109

Accessories

Model	Part Number
Low Flow Filter Regulator / Extractor	30006
Tube 8mm O.D. - 5mm I.D. (order by foot)	16506
Hose & Fitting - 8mm O.D. - 5mm I.D. - 12'	30041

Equipment Included

- 732MX Motor
- ER 8 UP Collet System (1/8" or 3mm)
- Collet Wrenches
- Low Flow Filter Regulator / Extractor
- Air Hoses
- Carrying Case

Standard Equipment

ER 8 UP Collet System (1/8" or 3mm collet.)

Oil-free 90 psi / 6.2 bar clean, dry air supply required.

Tel:+1.561.994.0500 • www.airturbinetools.com • ask@airturbinetools.com

Supply is subject to Air Turbine Technology Inc. (ATT) distributor policies and upon terms and conditions contained in the ATT distributor agreement. Subject to availability, change of specifications, price and terms without notice. Always use a 0.3 micron filter/extractor and check specified air flow. 6.2 Bar / 90 psi clean, dry, oil-free air only. Use eye protection and follow safety instructions. All specifications approximate. © 2024 Air Turbine Technology, Inc. All rights reserved.