

450HDE

Heavy Duty Motor Mount Series



The **450HDE** reaches into pockets and angles, ideal for cutting or finishing hard to reach work areas. The **450HDE's** sealed front-end prevents wet or dust contamination from getting inside the motor. This patented motor operates at governed speeds of **25,000, 30,000 or 40,000 RPM** with power to **0.88 HP (0.66 kW)**. Ideal for routing composites, plastics or wood and deburring, finishing or drilling metal at constant high speed. The rigid 41 mm O.D. steel barrel is easily fixtured for automation or combined with an end effector. Mountable area of Ø 41.15 mm OD by 63.5 mm. Ceramic and angular contact bearing options available.

450HDE Dimensions

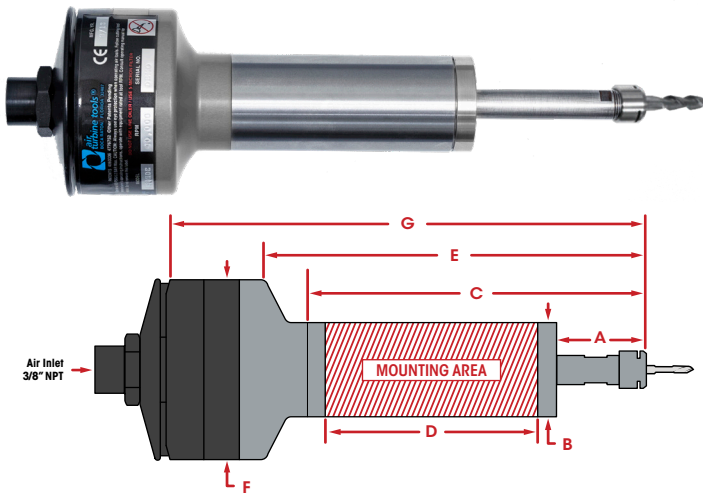

All fittings, couplings, and hoses must have a minimum of 8 mm internal diameter.

A	2.5" (63.5 mm)	D	2.5" (63.5 mm)	F	Ø 3.1" (79.74 mm)
B	Ø 1.62" (41.14 mm)	E	7.48" (189.99 mm)	G	9.06" (230.12 mm)
C	6.75" (171.45 mm)				

450HDE Specifications

Speed	25,000 RPM	30,000 RPM	40,000 RPM
Power Rating	0.76 HP (0.57 kW)	0.83 HP (0.62 kW)	0.88 HP (0.66 kW)
Inlet Air Pressure	90 psi (6.2 bar)		
Air Consumption Idle	13 CFM (6.14 L/s)	14 CFM (6.61 L/s)	
Air Consumption Working Flow	14 CFM (6.61 L/s) - 35 CFM (16.52 L/s)		
Air Hoses and Fittings Minimum Size	8 mm internal diameter		
Sound Level	Less Than 78 dBA		
Max Shank Capacity	ER11 - 1/4" (6 mm)		
Motor Weight	46 oz (1.3 kg)		

450HDE Series Part Numbers

ER11 - 1/4"		ER11 - 6 mm	
Speed RPM	Part Number	Speed RPM	Part Number
25,000	34480	25,000	34481
30,000	34482	30,000	34483
40,000	34484	40,000	34485

Accessories

Model	Part Number
High Flow Filter Regulator Extractor	30008
6' Air Supply Assembly w/Fitting	30012

Equipment Included

- 450HDE Motor
- ER11 Collet System (1/4" or 6 mm)
- Collet Wrenches
- 3/8" NPT Air Supply Fitting

Standard Equipment

ER11 collet system (1/4" or 6 mm collet).

Oil-free 90 psi / 6.2 bar clean, dry air supply required.

Tel:+1.561.994.0500 • www.airturbinetools.com • ask@airturbinetools.com

Supply is subject to Air Turbine Technology Inc. (ATT) distributor policies and upon terms and conditions contained in the ATT distributor agreement. Subject to availability, change of specifications, price and terms without notice. Always use a 0.3 micron filter/extractor and check specified air flow. 6.2 Bar / 90 psi clean, dry, oil-free air only. Use eye protection and follow safety instructions. All specifications approximate. © 2024 Air Turbine Technology, Inc. All rights reserved.

Air Turbine Motors® Quick User Notes and Setup Guide

450HDE - Heavy Duty Motor Mount Series



Initial Installation

Install a new dedicated clean air line from the included filter/regulator to your Air Turbine Motor® as shown below. **Ensure all air lines, couplings and fittings meet the minimum internal diameter (ID) of 8 mm.** Any connections smaller than 8 mm will restrict air flow and reduce power to your Air Turbine Motor®.

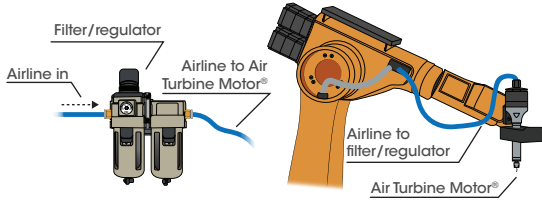

Air flow restrictions (such as air leaks and obstructions) will cause underpower performance and drag your tool through the material, damaging the bearings. **Some fittings with nominal internal dimensions may have an internal diameter passage that is smaller than stated and restrict air flow and power.** It only takes one fitting with an internal diameter that is too small to reduce air flow and power of your Air Turbine Motor®.

Air Requirements

Do not oil or lubricate. Use dry, clean, oil free 90 psi (6.2 bar) air supply only. Ensure there is sufficient volume of clean compressed air flow at 90 psi (6.2 bar) with **14 CFM (6.61 L/s) - 35 CFM (16.52 L/s)** to maintain working air consumption. Depending on application, consider peak or stall capacity consumption.

Our patented governor increases air flow on demand to keep rotation at the high speed when your tool starts to cut. Air pressure and flow volume must therefore be available on demand and remain constant with no drop over time or when cutting. Avoid pressure below 90 psi/6.2 bar, which causes the tool to be dragged through the material, causing rapid bearing wear and underpowered performance. Do not use more than 100 psi/6.9 bar pressure which will burst the turbine power producer. Air pressure and flow must remain constant with no drops under cutting load. Insufficient flow will cause the rotation of your tool to slow or stop suddenly, damaging the bearings. If a drop in psi (bar) occurs below 90 psi (6.2 bar), your compressor may not have enough CFM (L/s) to power the Air Turbine Motor® or there is a flow restriction in the air line.

Mounting your Air Turbine Motor® in a Lathe or Robot

It is very important your fixture is not clamped over the bearings. Incorrect positioning or over tightening of the clamp on your Air Turbine Motors® steel barrel results in pressure on the bearings causing premature failure. To avoid this error in installation refer to the dimensional drawing for your model on the other side of this page.

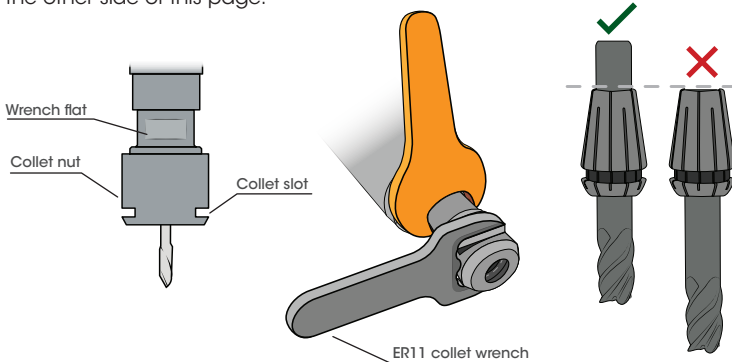

Scan to consult full user instructions.

Maintenance

Your Air Turbine Motor® must be run at least 10 minutes every 30 days from manufacture date to maintain optimal performance. Run at least 10 minutes before initial use. The airline must be impeccably clean with no coupling or hose smaller than 8 mm internal diameter. A 0.3 micron filter extractor regulator combination is a necessary accessory for Air Turbine Motors® Heavy Duty Motor Mount series to eliminate impurities in your air supply.

Contamination will damage your turbine components and require repair. **Filter elements need to be changed periodically and extractor drained in regular maintenance cycles.** Replacement elements and a repair service are available on our website.

Operation

Purge the line of contamination and run at least 10 minutes before initial use to ensure the bearing lubrication does not solidify.

Always monitor the air pressure gauge during operation of your Air Turbine Motor®. The key to successful high-speed machining and optimized tool performance is to program light passes at very high feed rates. Start with a light pass observing surface finish quality and gradually step down or increase your rate of advance for optimal cutting conditions. Do not try to cut too aggressively. You will overload your turbine causing your cutting tool to stall or drag in the material. Dragging your tool on the work or a sudden stop will cause stress to the bearings and force the grease out, which will require a repair.

Certain **rubber drilling applications** require that the material goes through a cooling process after extrusion. This prevents heat from transferring from the material to the cutting tool and the bearings of your 450HD. This cooling process will reduce the risk of premature failure.

Selecting the Correct Cutting Tool

Ensure your cutting tool is rated for the rotational speed you are using. The 450HDE runs at 25,000, 30,000 or 40,000 RPM. Your tool must also be balanced and truly concentric to operate at the high speed of Air Turbine Motors®. Incorrect tool selection results in unbalanced rotation or overloading, which will result in stress on the bearings and premature failure. The stick-out extension length of the cutting tool from your collet should optimally be no more than 3 times the diameter of your cutting tool.

Installation or Removal of Collet and Cutting Tool

1. Take the wrench included with your Air Turbine Motor® and insert it to the wrench flat of your Air Turbine Tool's shaft.
2. Take the ER11 collet wrench included with your Air Turbine Motor® and apply it on the collet slot as shown in the left diagram. Turn the wrench counterclockwise to release the current cutting tool.
3. After the cutting tool is free, continue to turn the collet nut counterclockwise with the ER11 collet wrench to fully remove the collet nut and release the existing collet. Remove the wrench from the shaft.
4. Remove the existing collet from the shaft and replace it with the new collet. Re-apply the collet nut by turning it clockwise on the shaft. **The 450HDE requires 7 ft-lbs of torque to tighten.**
5. Insert the new cutting tool by sliding it into the shaft of your tool. Ensure that the new cutting tool goes completely through the collet as shown to the left. **The stick-out extension length of the cutting tool from your collet should optimally be no more than 3 times the diameter of your cutting tool.**
6. Re-insert the wrench onto the wrench flat of your Air Turbine Tool's shaft and turn the collet nut clockwise until it's firmly held. **Do not over tighten the collet nut.** The 450HDE requires 7 ft-lbs of torque to tighten.
7. Insert the collet wrench into the collet nut and turn it clockwise to ensure the new collet and cutting tool is firmly held.



WARNING

Connection to air supply starts motor rotation. Do not connect air to your tool until installation is complete.

Tel:+1.561.994.0500 • www.airturbinetools.com • ask@airturbinetools.com