

MILL AT 65,000 TO 80,000 RPM

THE NEW 600X MIGHTY MINI SPINDLE

**Just connect 90 PSI
/ 6.2 BAR inlet**

Double Turbine Power

Low Profile For Clearance

**Through Spindle Air Supply
On Any Machine**

**No Heat. No Duty Cycle.
2 micron accuracy.**

The 600X's low air flow requirement facilitates through spindle air supply on any CNC.

The miniature profile makes programming easy and fits Bumotec and Chiron machines.

HSK 40/50/63, CAT40, BT30 and DIN40 available.

www.airturbinetools.com

MILL AT 65,000 TO 80,000 RPM

600X Series Specifications

The compact double turbine 600X spindle operates at **governed 65,000 rpm or 80,000 rpm**. Air Turbine Spindles® patented governor increases air flow volume to match cutting load maintaining rated high speed in cut. Now you get the required high SFM for small tools and 6-10x faster cycles.

The 600X's constant high speed optimizes your tool performance, reducing breakages on micro tools. Using only 5 cfm / 2.3 liters per second airflow the 600X series minimizes air consumption.

Our direct drive has only 2 moving parts - operating with no heat and zero thermal effects on accuracy.

2 micron, precision is certified assuring ultra precision. For improved micro tool performance and productivity add the 600X to your CNC magazine. All you need is a 90 PSI, 6.2 Bar dry air through your machine spindle.

HSK40 | 50 | 63, DIN40, CAT40, BT30 Available

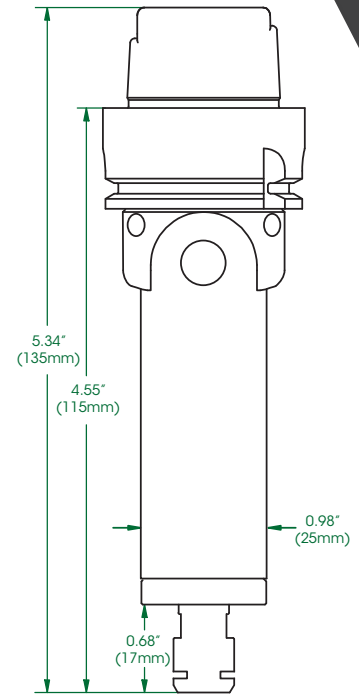

600XHSK-A40 Dimensions

General Specifications	600X Series	
Governed Speed RPM	65,000	80,000
Power Rating hp (kW)	0.15 (0.11)	
Inlet Air Pressure	90 PSI (6.2 Bar)	
Air Consumption Idle cfm (l/s)	3.5 cfm (1.6 l/s)	
Air Consumption Working Flow cfm (l/s)	5 cfm (2.3 l/s)	
Sound Level	Less Than 78 dBA	
Max Shank Capacity	ER 8 - 1/8" (3mm)	



Standard Equipment

ER 8 UP collet system (1/8" or 3mm collet standard – other sizes optional). Oil free 90 psi / 6.2 bar clean, dry air supply required.

Included Equipment

Filter Extractor Regulator (p/n #30006), collet, wrenches, hose, fittings and carrying case.

View more Air Turbine Spindles® at www.airturbinetools.com

Tel: +1.561.994.0500 • 1225 Broken Sound Parkway, NW, Suite D • Boca Raton, FL 33487 USA

All specifications approximate. © 2023 Air Turbine Tools, Inc. All rights reserved.