

450HDE - HD Mounted Series



The **450HDE** reaches into pockets and angles, ideal for cutting or finishing hard to reach work areas. The **450HDE's** sealed front-end prevents wet or dust contamination from getting inside the motor.

This patented motor operates at governed speeds of 25,000, 30,000 or 40,000 rpm with power to 0.88 hp (0.66 kW). Ideal for routing composites, plastics or wood and deburring, finishing or drilling metal at constant high speed. The rigid 41 mm O.D. steel barrel is easily fixtured for automation or combined with an end effector.

Dimensions

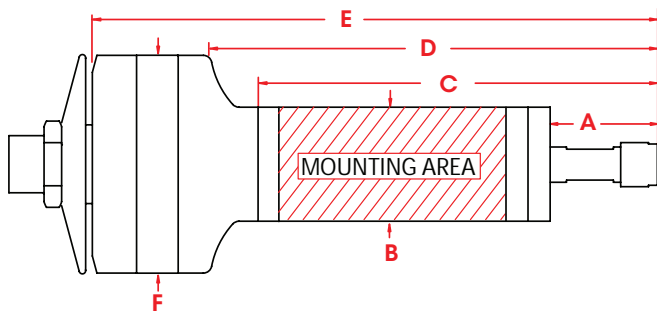
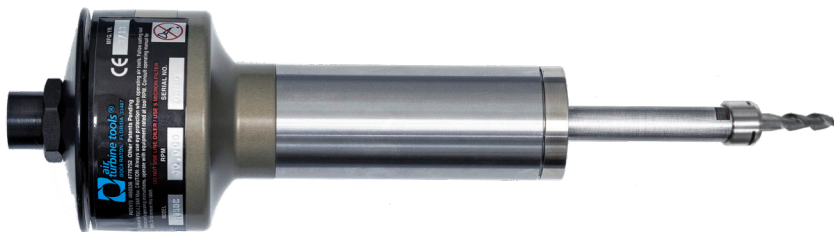

A	2.5" (63.5mm)	C	6.75" (171.45mm)	E	9.06" (230.12 mm)
B	1.62" (41.15mm)	D	7.48" (189.99mm)	F	3.10" (78.74mm)

450HDE Series

ER11 - 1/4"		ER11 - 6mm	
Speed RPM	Part #	Speed RPM	Part #
25,000	34480	25,000	34481
30,000	34482	30,000	34483
40,000	34484	40,000	34485

Accessories

Model	Part #
High Flow Filter Regulator Extractor	30008
6' Air Supply Assembly w/Fitting	30012

General Specifications

450HDE

Speed RPM	25,000 / 30,000 / 40,000
Power Rating hp (kW)	0.76 (0.57) / 0.83 (0.62) / 0.88 (0.66)
Inlet Air Pressure	90 PSI (6.2 Bar)
Air Consumption Idle cfm (l/s)	13 (6.1) / 14 (6.6) / 14 (6.6)
Air Consumption Working Flow cfm (l/s)	14 (6.61) - 35 (16.52)
Sound Level	Less Than 78 dBA
Max Shank Capacity	ER 11 - 1/4" (6mm)
Motor Weight	46 oz (1.30 kg)

Standard Equipment

Motor, ER 11 collet system (1/4" or 6mm collet standard - other sizes optional), collet wrenches, and 3/8" NPT air supply fitting.

Oil free 90PSI / 6.2BAR, clean, dry air supply required

Ceramic and angular contact bearing options available.

Tel: +1.561.994.0500 • Fax: +1.561.994.8097 • www.airturbinetools.com • info@airturbinetools.com

Use couplings / hoses with a minimum ID of 5mm for 720, 722, 730 and 732 motors, a minimum ID of 1/4" / 6mm for 202 motors, a minimum ID of 6.5mm for 725MX and 740MX motors, a minimum ID of 8mm for 450, 460 and 740XP motors, a minimum ID of 3/8" / 9.5mm for 210 motors and a minimum ID of 10mm for 450X and 460X motors. Always use a 0.3 micron filter and/or extractor where required and check specified psi or l/s air flow. Use 90 psi / 6.2 Bar clean, dry, oil-free air only. Use eye protection and follow safety instructions. Supply is subject to Air Turbine Tools Inc. terms and conditions of sale and distributor policies in effect for the time being. Subject to availability, change of specifications, price and terms without notice. All specifications approximate. Air Turbine Motors® is the registered trade name of Air Turbine Tools, Inc. © 2017 Air Turbine Tools, Inc. All rights reserved.