

Integration of the popular **DIN50** toolholder into the 650 spindle housing delivers constant high speed with ultra low vibration and improves accuracy and rigidity. Rigid steel construction in one piece with the toolholder also cuts the height of the unit. With *Air Turbine Spindles*® patented double turbine's extra power the 1.4 hp (1.04 kW) motor maintaining stable high speed and torque under load. The **650XVSDIN50** accelerates feed rates and cuts cycle times as a result of its low friction power unit with few moving parts. Rated governed speeds available are 25,000 to 40,000 rpm. Plenty of power to speed up your inches cut per minute. High cutting speeds are maintained at the periphery of your end mill or burr using the 650's unique governed performance to achieve a faster cycle time, a cleaner finished surface and more production on your CNC. **No Duty Cycle.**

The hex key inserted through the rear of the spindle switches the position of an internal screw - controlling flow of compressed air to supply one or both turbines operating at different speeds with single or double turbine power ratings.

### Dimensions

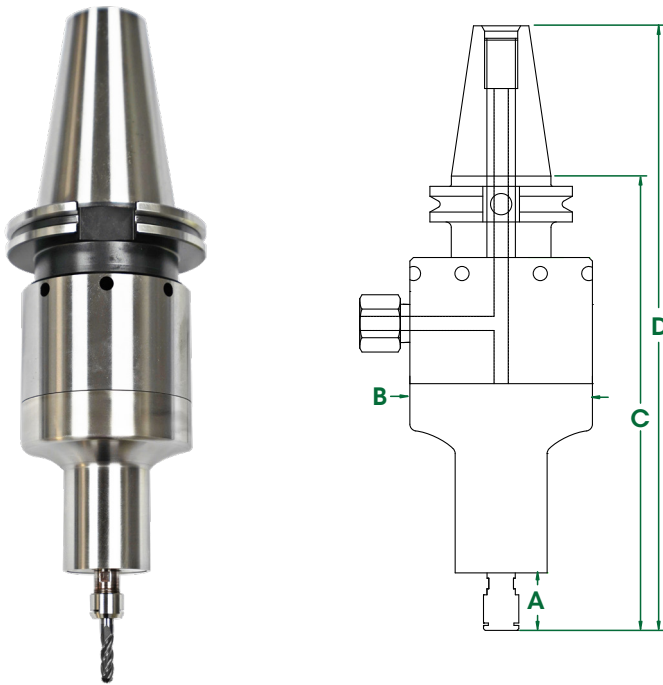

<b>A</b>	0.87" (22mm)	<b>C</b>	7.60" (193mm)
<b>B</b>	3.23" (82mm)	<b>D</b>	11.7" (296mm)

### 650XVSDIN50 Series Spindles

ER11 - 1/4"	ER11 - 6mm
<b>Part #</b>	<b>Part #</b>
66118	66119

### Accessories

Model	Part #
High Flow Filter / Regulator / Extractor with 1/2" NPT	30084
Tube 16mm O.D. - 10mm I.D. (order by foot)	16516
Hose & Fitting - 16mm O.D. - 10mm I.D. - 12'	30046

### General Specifications

### 650XVSDIN50

<b>Speed RPM</b>	25,000 - 40,000
<b>Power Rating hp (kW)</b>	0.8 (0.60) - 1.4 (1.04)
<b>Inlet Air Pressure</b>	90 PSI (6.2 Bar)
<b>Air Consumption Idle cfm (l/s)</b>	11 (5.2) - 18 (8.49)
<b>Air Consumption Working Flow cfm (l/s)</b>	14 (6.60) - 40 (18.89)
<b>Sound Level</b>	Less Than 78 dBA
<b>Max Shank Capacity</b>	ER 11 - 1/4" (6mm)
<b>Spindle Weight</b>	118.4 oz (3.34 kg)

### Standard Equipment

Spindle, combo filter extractor (p/n #30084), collet, wrenches, hose and fittings, plug (for alternate air inlet not in use) and carrying case. ER 11 collet system (1/4" or 6mm collet standard - other sizes optional).

Oil free 90 psi / 6.2 bar, clean, dry air supply required.

Tel:+1.561.994.0500 • Fax: +1.561.994.8097 • [www.airturbinetools.com](http://www.airturbinetools.com) • [info@airturbinetools.com](mailto:info@airturbinetools.com)

Do not use couplings / hoses less than 1/4" / 6mm Internal Diameter (ID). Use couplings / hoses with a minimum ID of 6.5mm for 602, 602X and 625 spindles, a minimum ID of 8mm for 625X, 650, 660 spindles and (602, 602X, 625, 625X, 650 and 660 spindles with TMA) and a minimum ID of 10mm for 650X, 660X spindles and (650X and 660X spindles with TMA). Always use a 0.3 micron filter and/or extractor where required and check specified psi or l/s air flow. Use 90 psi / 6.2 Bar clean, dry, oil-free air only. Use eye protection and follow safety instructions. Supply is subject to Air Turbine Tools Inc. terms and conditions of sale and distributor policies in effect for the time being. Subject to availability, change of specifications, price and terms without notice. All specifications approximate. Air Turbine Spindles® is the registered trade name of Air Turbine Tools, Inc. © 2019 Air Turbine Tools, Inc. All rights reserved.