

# 625XBT40 - Spindle Series



The patented double turbine **625XBT40** delivers constant high speeds under load - 30,000 to 50,000 rpm, < 0.78 hp (0.58 kW).

Speed up your cycle times with this compact and powerful spindle. Ideal for contouring, mold making, milling, finishing and drilling with small tools. Governor control maintains constant high speed and power under load. Direct drive means low heat, no duty cycle and super reliability.

Selectable rear or side air feed.

## Dimensions

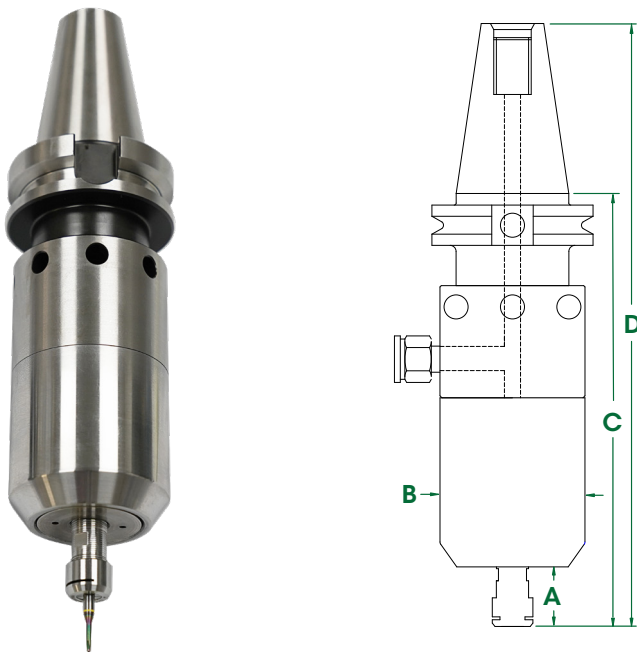

<b>A</b>	0.87" (22mm)	<b>C</b>	7.24" (184mm)
<b>B</b>	2.24" (57mm)	<b>D</b>	9.80" (249mm)

## 625XBT40 Series Spindles

ER11 - 1/4"		ER11 - 6mm	
Speed RPM	Part #	Speed RPM	Part #
30,000	64144	30,000	64145
40,000	64146	40,000	64147
50,000	64382	50,000	64383

## Accessories

Model	Part #
High Flow Filter / Regulator / Extractor	30008
Tube 12mm O.D. - 8mm I.D. (order by foot)	16509
Hose & Fitting - 12mm O.D. - 8mm I.D. - 12'	30045

## General Specifications

## 625XBT40

Speed RPM	30,000 / 40,000 / 50,000
Power Rating hp (kW)	0.72 (0.54) / 0.74 (0.55) / 0.76 (0.57)
Inlet Air Pressure	90 PSI (6.2 Bar)
Air Consumption Idle cfm (l/s)	19 (8.97) / 20 (9.44) / 20 (9.44)
Air Consumption Working Flow cfm (l/s)	22 (10.38) - 30 (14.16)
Sound Level	Less Than 78 dBA
Max Shank Capacity	ER 11 - 1/4" (6mm)
Spindle Weight	96 oz (2.72 kg)

## Standard Equipment

Spindle, combo filter extractor (p/n #30008), collet, wrenches, hose and fittings, plug (for alternate air inlet not in use) and carrying case. ER 11 collet system (1/4" or 6mm collet standard - other sizes optional).

Oil free 90 psi / 6.2 bar, clean, dry air supply required.

Tel: +1.561.994.0500 • Fax: +1.561.994.8097 • [www.airturbinetools.com](http://www.airturbinetools.com) • [info@airturbinetools.com](mailto:info@airturbinetools.com)

Do not use couplings / hoses less than 1/4" / 6mm Internal Diameter (ID). Use couplings / hoses with a minimum ID of 6.5mm for 602, 602X and 625 spindles, a minimum ID of 8mm for 625X, 650, 660 spindles and (602, 602X, 625, 625X, 650 and 660 spindles with TMA) and a minimum ID of 10mm for 650X, 660X spindles and (650X and 660X spindles with TMA). Always use a 0.3 micron filter and/or extractor where required and check specified psi or l/s air flow. Use 90 psi / 6.2 Bar clean, dry, oil-free air only. Use eye protection and follow safety instructions. Supply is subject to Air Turbine Tools Inc. terms and conditions of sale and distributor policies in effect for the time being. Subject to availability, change of specifications, price and terms without notice. All specifications approximate. Air Turbine Spindles® is the registered trade name of Air Turbine Tools, Inc. © 2019 Air Turbine Tools, Inc. All rights reserved.