

625LJS (50mm) - Spindle Series

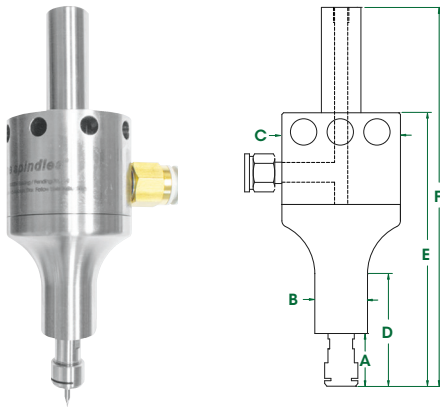

With vibration at just 0.4mm/sec the **625LJS (50mm)** produces superb accuracy and fast results. The powerful **625LJS (50mm)** is designed for close workpiece operations and machines with very short z-axis travel. Compact and powerful *Air Turbine Spindles®* 625 unit delivers patented constant governed high speed operation under load up to 0.50 hp / 0.37 kW at 30,000, 40,000 or 50,000 rpm. This results in cuts faster and cleaner - speeding up cycle times and achieving major savings. Fewer moving parts means less vibration and less repairs. There are no gears or vanes to lubricate or burn up and the ceramic grease packed bearings are durable. Specify angular bearings for drilling. Totally oil free operation eliminates work piece contamination and oil lubrication using 90 PSI (6.2 Bar) dry clean oil free air. The JS version is easy to mount with your selection of toolholder configuration and two selectable air inlet options (through shank or side airfeed NPT) (patent pending). **No Duty Cycle.**

Dimensions



A	1.00" (25mm)	D	2.16" (55mm)
B	1.00" (25mm)	E	5.22" (133mm)
C	2.25" (57mm)	F	7.22" (183mm)

625LJS (50mm) Series Spindles

ER11 - 1/4"		ER11 - 6mm	
Speed RPM	Part #	Speed RPM	Part #
30,000	65096	30,000	65097
40,000	65098	40,000	65099
50,000	65100	50,000	65101

Accessories

Model	Part #
High Flow Filter / Regulator / Extractor	30008
Tube 10mm O.D. - 6.5mm I.D. (order by foot)	16508
Hose & Fitting - 10mm O.D. - 6.5mm I.D. - 12'	30043

General Specifications

625LJS (50mm)

Speed RPM	30,000 / 40,000 / 50,000
Power Rating hp (kW)	0.40 (0.30) / 0.45 (0.34) / 0.50 (0.37)
Inlet Air Pressure	90 PSI (6.2 Bar)
Air Consumption Idle cfm (l/s)	10.5 (4.9) / 11 (5.2) / 11 (5.2)
Air Consumption Working Flow cfm (l/s)	11 (5.2) - 20 (9.4)
Sound Level	Less Than 78 dBA
Max Shank Capacity	ER 11 - 1/4" (6mm)
Spindle Weight	52 oz (1.47 kg)

Standard Equipment

Spindle, combo filter extractor (p/n #30008), collet, wrenches, hose and fittings, plug (for alternate air inlet not in use) and carrying case. ER 11 collet system (1/4" or 6mm collet standard - other sizes optional). 3/4" or 20mm shank standard (Metric Shank comes with metric collet, Inch Shank with inch collet). Oil free 90 psi / 6.2 bar, clean, dry air supply required.

Tel: +1.561.994.0500 • Fax: +1.561.994.8097 • www.airturbinetools.com • info@airturbinetools.com

Do not use couplings / hoses less than 1/4" / 6mm Internal Diameter (ID). Use couplings / hoses with a minimum ID of 6.5mm for 602, 602X and 625 spindles, a minimum ID of 8mm for 625X, 650, 660 spindles and (602, 602X, 625, 625X, 650 and 660 spindles with TMA) and a minimum ID of 10mm for 650X, 660X spindles and (650X and 660X spindles with TMA). Always use a 0.3 micron filter and/or extractor where required and check specified psi or l/s air flow. Use 90 psi / 6.2 Bar clean, dry, oil-free air only. Use eye protection and follow safety instructions. Supply is subject to Air Turbine Tools Inc. terms and conditions of sale and distributor policies in effect for the time being. Subject to availability, change of specifications, price and terms without notice. All specifications approximate. Air Turbine Spindles® is the registered trade name of Air Turbine Tools, Inc. © 2019 Air Turbine Tools, Inc. All rights reserved.