

Compact, the **602JS** delivers governed constant high speeds under load. Rated speeds are 40,000, 50,000, 65,000 and \*90,000 rpm. Ideal for engraving, marking, slotting, drilling and finishing with small tools the 602 speeds up cycle times – cutting cost and accelerating production. *Air Turbine Spindles®*. patented motors maintain high speed while cutting with no gears, vanes or brushes to burn up. Using dry clean, oil free, 90 psi (6.2 Bar) compressed air the 602 requires no lubrication and emits no oil mist. With fewer moving parts and low friction and utilizing ceramic bearings the 602 is a precise and reliable favorite. **No Duty Cycle.**

### Dimensions

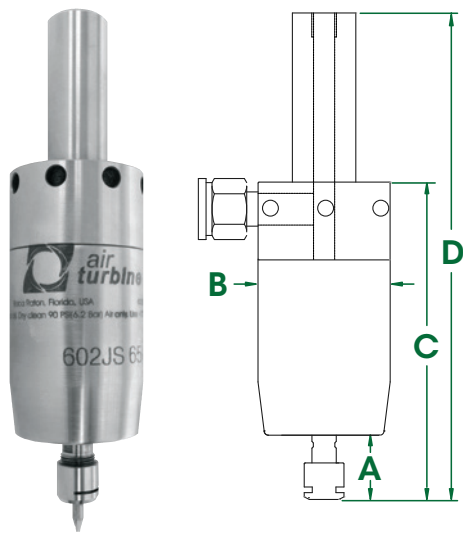

<b>A</b>	0.76" (19mm)	<b>C</b>	3.75" (95mm)
<b>B</b>	1.56" (40mm)	<b>D</b>	5.75" (146mm)

### 602JS Series Spindles

ER8 - 1/8"		ER8 - 3mm	
Speed RPM	Part #	Speed RPM	Part #
40,000	64250	40,000	64251
50,000	64252	50,000	64253
65,000	64254	65,000	64255
90,000	64256	90,000	64257

### Accessories

Model	Part #
High Flow Filter / Regulator / Extractor	30008
Tube 10mm O.D. - 6.5mm I.D. (order by foot)	16508
Hose & Fitting - 10mm O.D. - 6.5mm I.D. - 12'	30043

\*90,000 rpm 602 version is recommended for only special applications with micro end mills. Please call +1.561.994.0500 for more information.

### General Specifications

### 602JS

Speed RPM	40,000 / 50,000 / 65,000 / 90,000
Power Rating hp (kW)	0.15 (0.11) / 0.2 (0.15) / 0.2 (0.15) / 0.2 (0.15)
Inlet Air Pressure	90 PSI (6.2 Bar)
Air Consumption Idle cfm (l/s)	4.5 (2.1) / 4.5 (2.1) / 4.5 (2.1) / 5 (2.4)
Air Consumption Working Flow cfm (l/s)	5 (2.36) - 6 (3.30)
Sound Level	Less Than 78 dBA
Max Shank Capacity	ER 8 - 1/8" (3mm)
Spindle Weight	23.2 oz (0.66 kg)

### Standard Equipment

Spindle, combo filter extractor (p/n #30008), collet, wrenches, hose and fittings, plug (for alternate air inlet not in use) and carrying case. ER 8 collet system (1/8" or 3mm collet standard - other sizes optional). 3/4" or 20mm shank standard (Metric Shank comes with metric collet, Inch Shank with inch collet). Oil free 90 psi / 6.2 bar, clean, dry air supply required.

Tel: +1.561.994.0500 • Fax: +1.561.994.8097 • [www.airturbinetools.com](http://www.airturbinetools.com) • [info@airturbinetools.com](mailto:info@airturbinetools.com)

Do not use couplings / hoses less than 1/4" / 6mm Internal Diameter (ID). Use couplings / hoses with a minimum ID of 6.5mm for 602, 602X and 625 spindles, a minimum ID of 8mm for 625X, 650, 660 spindles and (602, 602X, 625, 625X, 650 and 660 spindles with TMA) and a minimum ID of 10mm for 650X, 660X spindles and (650X and 660X spindles with TMA). Always use a 0.3 micron filter and/or extractor where required and check specified psi or l/s air flow. Use 90 psi / 6.2 Bar clean, dry, oil-free air only. Use eye protection and follow safety instructions. Supply is subject to Air Turbine Tools Inc. terms and conditions of sale and distributor policies in effect for the time being. Subject to availability, change of specifications, price and terms without notice. All specifications approximate. Air Turbine Spindles® is the registered trade name of Air Turbine Tools, Inc. © 2017 Air Turbine Tools, Inc. All rights reserved.