

Integration of the popular **BT40** toolholder into 602 spindle housing cuts vibration and improves accuracy and rigidity. Rigid steel construction in one piece with the toolholder also cuts the height of the unit. *Air Turbine Spindles®* patented constant governed high speed operation under load cuts faster and cleaner - speeding up cycle times and achieving major savings. Your solution for fast cutting with small end mills and drills, finishing or marking. High speed cutting improves finish quality and accuracy with a fast light pass of your tool. At 40,000, 50,000, 65,000 or *90,000 rpm tool coatings achieve the required temperatures to extend endmill life saving money as well as accelerating production. 0.2 hp (0.15 kW). **No Duty Cycle.**

Dimensions

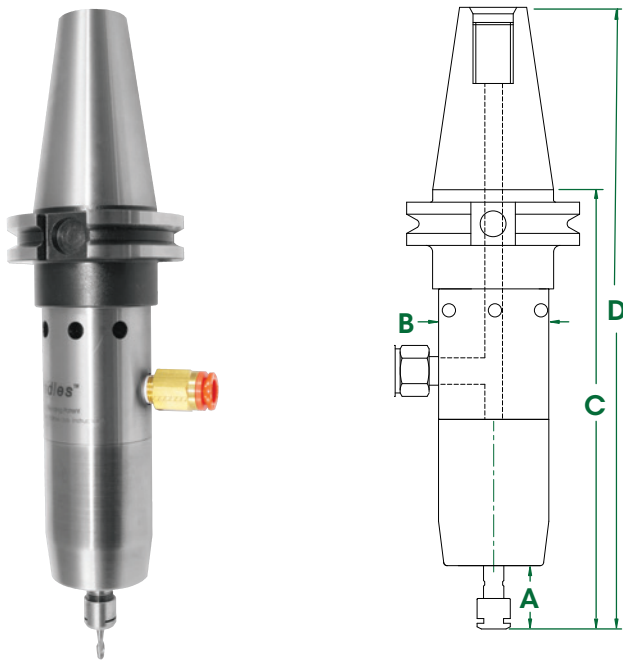

A	0.75" (19mm)	C	6.42" (163mm)
B	1.57" (40mm)	D	8.90" (226mm)

602BT40 Series Spindles

ER8 - 1/8"		ER8 - 3mm	
Speed RPM	Part #	Speed RPM	Part #
40,000	64266	40,000	64267
50,000	64268	50,000	64269
65,000	64270	65,000	64271
90,000	64272	90,000	64273

Accessories

Model	Part #
High Flow Filter / Regulator / Extractor	30008
Tube 10mm O.D. - 6.5mm I.D. (order by foot)	16508
Hose & Fitting - 10mm O.D. - 6.5mm I.D. - 12'	30043

*90,000 rpm 602 version is recommended for only special applications with micro end mills. Please call +1.561.994.0500 for more information.

General Specifications

602BT40

Speed RPM	40,000 / 50,000 / 65,000 / 90,000
Power Rating hp (kW)	0.15 (0.11) / 0.2 (0.15) / 0.2 (0.15) / 0.2 (0.15)
Inlet Air Pressure	90 PSI (6.2 Bar)
Air Consumption Idle cfm (l/s)	4.5 (2.1) / 4.5 (2.1) / 4.5 (2.1) / 5 (2.4)
Air Consumption Working Flow cfm (l/s)	5 (2.36) - 6 (3.30)
Sound Level	Less Than 78 dBA
Max Shank Capacity	ER 8 - 1/8" (3mm)
Spindle Weight	46.4 oz (1.32 kg)

Standard Equipment

Spindle, combo filter extractor (p/n #30008), collet, wrenches, hose and fittings, plug (for alternate air inlet not in use) and carrying case. ER 8 collet system (1/8" or 3mm collet standard - other sizes optional).

Oil free 90 psi / 6.2 bar, clean, dry air supply required.

Tel: +1.561.994.0500 • Fax: +1.561.994.8097 • www.airturbinetools.com • info@airturbinetools.com

Do not use couplings / hoses less than 1/4" / 6mm Internal Diameter (ID). Use couplings / hoses with a minimum ID of 6.5mm for 602, 602X and 625 spindles, a minimum ID of 8mm for 625X, 650, 660 spindles and (602, 602X, 625, 625X, 650 and 660 spindles with TMA) and a minimum ID of 10mm for 650X, 660X spindles and (650X and 660X spindles with TMA). Always use a 0.3 micron filter and/or extractor where required and check specified psi or l/s air flow. Use 90 psi / 6.2 Bar clean, dry, oil-free air only. Use eye protection and follow safety instructions. Supply is subject to Air Turbine Tools Inc. terms and conditions of sale and distributor policies in effect for the time being. Subject to availability, change of specifications, price and terms without notice. All specifications approximate. Air Turbine Spindles® is the registered trade name of Air Turbine Tools, Inc. © 2017 Air Turbine Tools, Inc. All rights reserved.