

Differences you will feel immediately: Speed does the cutting with low stress. The patented 45° **2545SVF** angle tool with slide valve control and front exhaust is designed with the turbine in its angle head and no gears. Light weight with low vibration provides superior comfort.

Just 2 moving parts for superior reliability with our totally oil-free and maintenance-free mechanism.

Select governed 30,000 or 40,000 rpm for deburring and weld removal.

Dimensions

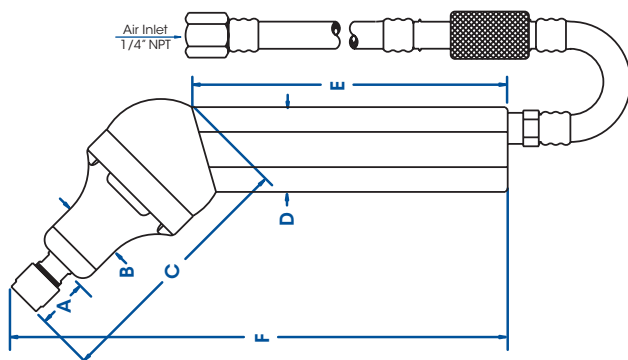

A	0.86" (21.84mm)	C	4.13" (104.90mm)	E	5.12" (130.05mm)
B	1.00" (25.40mm)	D	1.37" (34.80mm)	F	8.06" (205.72mm)

2545SVF Series

1/4"		6mm	
Speed RPM	Part #	Speed RPM	Part #
30,000	35532	30,000	35533
40,000	35542	40,000	35543

Accessories

Model	Part #
High Flow Filter	30004
High Flow Filter / Regulator	30003
High Flow Filter / Regulator / Extractor	30008
5' Air Supply Assembly w/Fitting for SV Models	34207

Standard Equipment

Hand Tool, 1/4" or optional 6mm collet, collet wrenches, front exhaust. 5' air supply assembly with slide valve and 1/4" NPT air supply fitting.

Oil free 90 psi / 6.2 bar, clean, dry air supply required.

General Specifications

2545SVF

Speed RPM	30,000 / 40,000
Power Rating hp (kW)	0.4 (0.30) / 0.45 (0.34)
Inlet Air Pressure	90 PSI (6.2 Bar)
Air Consumption Idle cfm (l/s)	10 (4.72) / 13 (6.14)
Air Consumption Working Flow cfm (l/s)	11 (5.19) - 20 (9.44)
Sound Level	Less Than 67 dBA
Max Shank Capacity	1/4" (6mm)
Hand Tool Weight	18oz (0.50kg)

Vibration Statistics

Time to reach EAV 2.5 m/s² A(8)
64 hours, 11 minutes

Time to reach ELV 5 m/s² A(8)
256 hours, 41 minutes

Vibration magnitude m/s² r.m.s
0.88

Tel: +1.561.994.0500 • Fax: +1.561.994.8097 • www.airturbinetools.com • info@airturbinetools.com

Do not use couplings/hoses less than 1/4" / 6mm Internal Diameter (ID). With 230, 525X, and 3090 units use a minimum 3/8" / 9.5mm ID coupling/hose. For 230X units use a minimum 10mm ID coupling/hose. Always use a 5 micron filter and/or extractor where required and check specified PSI or l/s air flow. Use 6.2 Bar / 90 psi clean, dry, oil-free air only. Use eye protection and follow safety instructions. Supply is subject to Air Turbine Technology Inc. (ATT) distributor policies and upon terms contained in the ATT distributor agreement. Subject to availability, change of specifications, price and terms without notice. All specifications approximate.
© 2014 Air Turbine Technology, Inc. All rights reserved.