

The **650CAT50** delivers governed constant high speeds under load - **25,000 and 40,000 rpm, < 0.88 hp (0.66 kW)**. Robust and reliable, with double front ceramic bearings, the 650 Series is ideal for heavier duty applications and milling hard materials in corners.

The governor controlled turbine maintains rated high speed, optimizing tool performance and life. Effective in all materials, including tool steel, titanium and ceramic. Ultra low vibration and no heat in 24/7 operation.

Selectable rear or side air feed on each spindle.
Automatic Loading from the magazine on all machines.

Dimensions

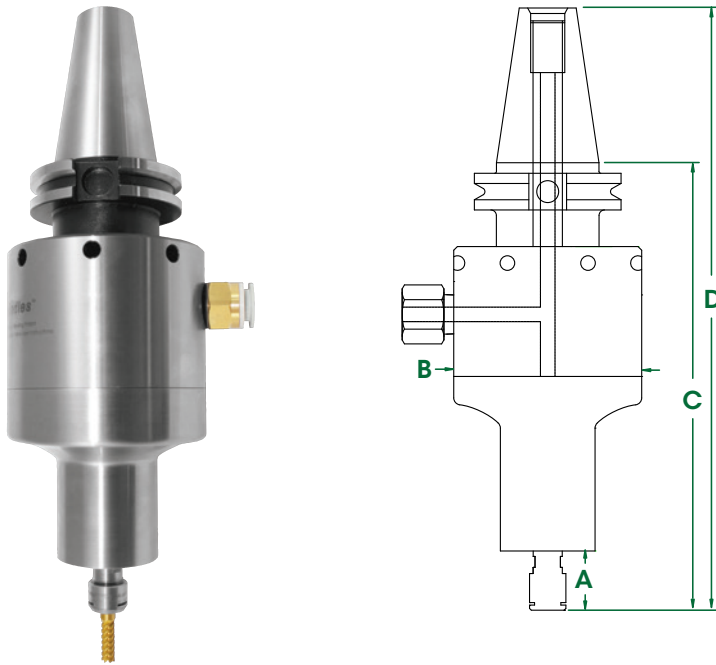

A	0.87" (22mm)	C	7.13" (181mm)
B	3.23" (82mm)	D	11.2" (284mm)

650CAT50 Series Spindles

ER11 - 1/4"		ER11 - 6mm	
Speed RPM	Part #	Speed RPM	Part #
25,000	64220	25,000	64221
40,000	64224	40,000	64225

Accessories

Model	Part #
High Flow Filter / Regulator / Extractor	30008
Tube 12mm O.D. - 10mm I.D. (order by foot)	16509
Hose & Fitting - 12mm O.D. - 10mm I.D. - 12'	30045

General Specifications

650CAT50

Speed RPM	25,000 / 40,000
Power Rating hp (kW)	0.80 (0.60) / 0.88 (0.66)
Inlet Air Pressure	90 PSI (6.2 Bar)
Air Consumption Idle cfm (l/s)	13 (6.1) / 14 (6.6)
Air Consumption Working Flow cfm (l/s)	14 (6.60) - 35 (16.5)
Sound Level	Less Than 78 dBA
Max Shank Capacity	ER 11 - 1/4" (6mm)
Spindle Weight	112.8 oz (3.20 kg)

Standard Equipment

Spindle, combo filter extractor (p/n #30008), collet, wrenches, hose and fittings, plug (for alternate air inlet not in use) and carrying case. ER 11 collet system (1/4" or 6mm collet standard - other sizes optional).

Oil free 90 psi / 6.2 bar, clean, dry air supply required.

Tel: +1.561.994.0500 • Fax: +1.561.994.8097 • www.airturbinetools.com • info@airturbinetools.com

Do not use couplings / hoses less than 1/4" / 6mm Internal Diameter (ID). Use couplings / hoses with a minimum ID of 6.5mm for 602, 602X and 625 spindles, a minimum ID of 8mm for 625X, 650, 660 spindles and (602, 602X, 625, 625X, 650 and 660 spindles with TMA) and a minimum ID of 10mm for 650X, 660X spindles and (650X and 660X spindles with TMA). Always use a 0.3 micron filter and/or extractor where required and check specified psi or l/s air flow. Use 90 psi / 6.2 Bar clean, dry, oil-free air only. Use eye protection and follow safety instructions. Supply is subject to Air Turbine Tools Inc. terms and conditions of sale and distributor policies in effect for the time being. Subject to availability, change of specifications, price and terms without notice. All specifications approximate. Air Turbine Spindles® is the registered trade name of Air Turbine Tools, Inc. © 2017 Air Turbine Tools, Inc. All rights reserved.