

The Model **200SV** contrasts with our **201SV** and **0145SSV** models. The statistics are great. The **200SV** weighs only 5.4 oz/.15 kg with a power rating of 0.3 hp/.22 kW. Maintaining a constant speed at 50,000 rpm under variable load, the **200SV** delivers greater accuracy and a faster cleaner finish with the lowest vibration available - under 2,2mm/s² - running under 67 dBA noise level. The **200SV** is rugged and a completely oil free precision tool with no vanes to repair or lubricate. No maintenance is required - just clean, dry air supply. **Air turbine tools®** give you lower operating costs, including less repairs, up to 30% savings on compressed air usage and longer cutting tool life. The **200SV** is a quality precision tool.

Model 200SV

0.3 hp
0.22 kW

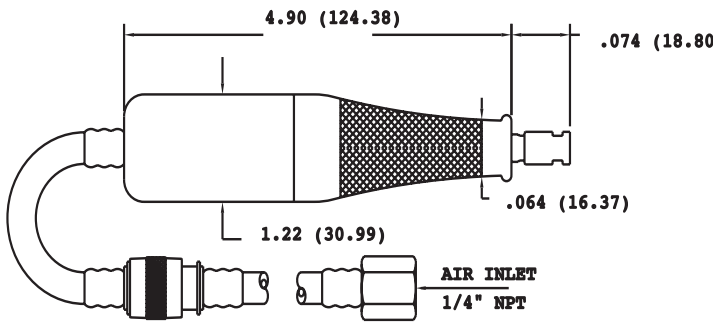

1/8"	No Brake	With Brake
Speed	Part #	Part #
50,000 rpm	32060	32062

3mm	No Brake	With Brake
Speed	Part #	Part #
50,000 rpm	32061	32063

Weight: 5.4 oz/ .15 kg

Standard Equipment: Hand tool, collet, wrenches, rear exhaust, 5' air supply assembly with slide valve and 1/4" NPT air supply fitting. 1/8" / 3mm collet.

Oil free 90PSI / 6.2BAR, clean, dry air supply.

General Specifications	CE	200SV	MADE IN THE USA
Speed RPM		50,000	
Power Rating HP (KW)		.3 (.22)	
Inlet Air Pressure		90 PSI (6.2 Bar)	
Air Consumption-Idle cfm (L/s)		4 (1.88)	
Air Consumption-Working cfm (l/s)		6 (2.83) - 9 (4.24)	
TIR Collet Held Shank		Less than .001" (.03mm)	
Sound Level		Less than 67 dBA	
Standard Shank Capacity		1/8" (3mm)	

Accessories

Low Flow Filter	30002
Low Flow Filter / Regulator	30001
Collet Guard	30070
Foot Pedal Control	30030

