

The light powerful 206XDME's high rotational speed removes material cleanly. The 206XDME is a feather-weight that packs a punch. Get into tight areas with extended reach and governed high speed to finish cleaner and faster. Comfortable, quiet, clean cutting, the **206XDME** transforms the work experience, and delivers improved finish quality. Less repairs with no vanes. The totally oil free direct drive motor is durable and the unit weighs just 17oz.

**Model 206XDME**

**0.3 hp**  
**0.22kW**

Double Front Bearings Standard



Automatic Brake Standard

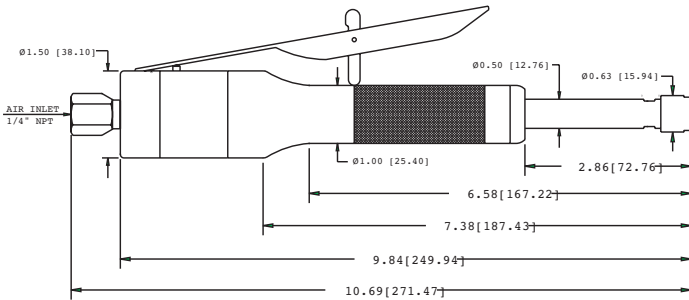



1/4"	
Speed	Part #
40,000 rpm	42008

6mm	
Speed	Part #
40,000 rpm	42009

**Weight : 17.0oz / 0.48kg**

**Standard Equipment Included:** 1/4" or optional 6mm collet, collet wrenches, rear exhaust, and 1/4" NPT air supply fitting. Oil free 90 psi / 6.2 bar dry, clean air supply required at rated CFM/LS. Do not use couplings or hoses less than 1/4" / 6mm diameter.

General Specifications	  
Speed RPM	40,000
Power Rating HP (KW)	0.3 (0.22)
Inlet Air Pressure	90 PSI (6.2 Bar)
Air Consumption - Idle cfm (L/s)	6 (2.83)
Air Consumption - Working cfm (L/s)	7 (3.30) - 10 (4.72)
TR Collet	Less than .001" (.03 mm)
Sound Level	Less than 67 dBA
Standard Shank Capacity	1/4" (6mm)

Accessories	Part#
High Flow Filter	30004
High Flow Filter / Regulator	30003
5' Air Supply Assy w/Fitting	30010
8' Air Supply Assy w/Fitting	30011