

Integration of the popular DIN40 toolholder into the 650 spindle housing delivers constant high speed with ultra low vibration and improves accuracy and rigidity. Rigid steel construction in one piece with the toolholder also cuts the height of the unit. The 650DIN40 is a workhorse with up to 0.88HP / 0.66KW at 25,000rpm, 30,000rpm or 40,000 rpm. Super precision at 0.0002" / 0.00508mm. with H6 Shank Tolerance. In 24 hour operation the patented governed high speed 650DIN40 delivers constant high speed and torque under load with high reliability and accuracy as a result of its low friction power unit with few moving parts. Plenty of power to speed up your inches cut per minute. High cutting speeds are maintained at the periphery of your end mill or burrusing the the 650's unique governed performance to achieve a faster cycle time.

Model 650DIN-(69871)

0.88 hp
0.66 kW

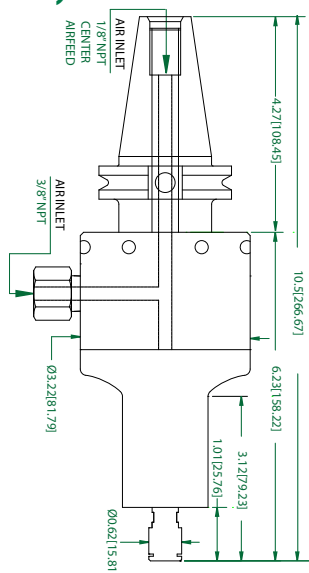



1/4"		6mm	
Speed	Part #	Speed	Part #
25,000 rpm	64162	25,000 rpm	64163
30,000 rpm	64164	30,000 rpm	64165
40,000 rpm	64166	40,000 rpm	64167

Weight: 112.8oz / 3.20kg

Standard Equipment: Spindle, combo filter extractor, collet, wrenches, plug (for alternate air inlet not in use) and carrying case.

ER11 collet system standard (1/4" or 6mm collet standard - other sizes optional). Oil free 90PSI / 6.2BAR, clean, dry air supply.

General Specifications	650DIN-(69871)  		
	25,000	30,000	40,000
Speed RPM	25,000	30,000	40,000
Power Rating HP (KW)	.76 (.57)	.88 (.66)	.88 (.66)
Inlet Air Pressure	90 PSI (6.2 Bar)		
Air Consumption-Idle cfm (L/s)	13 (6.1)	14 (6.6)	14 (6.6)
Air Consumption-Working cfm (L/s)	14 (6.60) - 35 (16.5)		
TIR Collet Held Shank	Less Than 0.0002" (0.005mm)		
Sound Level	Less than 67 dBa		
Standard Shank Capacity	1/4" (6mm)		

Accessories
High Flow Filter/Regulator/Extractor **Part#** 30008

Hose & Fitting Assemblies **Part#** 16509
Tube 12mm O.D. - 8mm I.D.
(order by the foot)
Hose & Fitting - 6' **Part#** 30044
Hose & Fitting - 12' **Part#** 30045

TMA Autochanger **Part#**
Haas 36220
Fadal 36223
Hurco 36272
Hurco 40 Taper 66MM 36275
Universal 36229